

CHAPTER 8
COLOURS AND FLAGS
SECTION 1
GENERAL

DEFINITIONS

1. **Cased Colours.** Colours enclosed in a fabric case.
2. **Colours.** Consecrated ceremonial flags which are carried by, and mark the identity of, Canadian Armed Forces (CAF) formations and units, and include: Queen's Colours; Standards; Guidons; and Command, College and Regimental Colours.
3. **Dipping the Colours.** Rendering a salute by lowering the Colours to the entitled dignitaries detailed in A-AD-200-000/AG-000, Honours, Flags and The Heritage Structure of the Canadian Forces (soon to become A-DH-200-000/AG-000; The Heritage Structure of the CAF).
4. **Flags.** Pieces of bunting or other material, attachable to a staff or halyard, and used as a means of identification or for signalling. As a generic term, it includes Colours. In this chapter it specifically means only those non-consecrated flags which may be carried on parade, i.e., Commemorative (Royal) banners, the National Flag, the CAF Ensign and Command Flags. Commemorative (Royal) Banners are not paired or grouped with other flags and are not dipped in a salute. Branch and Unit camp Flags are strictly marker flags and are not carried on parades A-AD-200-000/AG-000, Honours, Flags and The Heritage Structure of the Canadian Forces (soon to become A-DH-200-000/AG-000; The Heritage Structure of the CAF, Chapter 4, sections 6 & 7).
5. **Let Fly the Colours.** Releasing the Colours to fly free, either as a salute to dignitaries not entitled to the Royal Salute as detailed in A-AD-200-000/AG-000, Honours, Flags and The Heritage Structure of the Canadian Forces (soon to become A-DH-200-000/AG-000; The Heritage Structure of the CAF), or to allow free identification of the flag.
6. **Uncased Colours.** Colours removed from the fabric case.

PARADING COLOURS AND FLAGS

7. Guidelines for when Colours and flags may be carried on parade are given in A-AD-200-000/AG-000, Honours, Flags and The Heritage Structure of the Canadian Forces soon to become A-DH-200-000/AG-000; The Heritage Structure of the CAF.
8. The Colour drill in this chapter applies equally to flags when carried on parade, unless specifically noted.

DRAPING THE COLOURS

9. Colours only shall be draped for funerals (see Chapter 11). The Colour is draped with a piece of black crepe 2.5 m long and 33 cm wide, tied in a bow at the base of the pike head so that the span of the bow is 30 cm. The ends, cut on the bias, should hang half-way down the sleeve of the Colour (Figure 8-1-1).

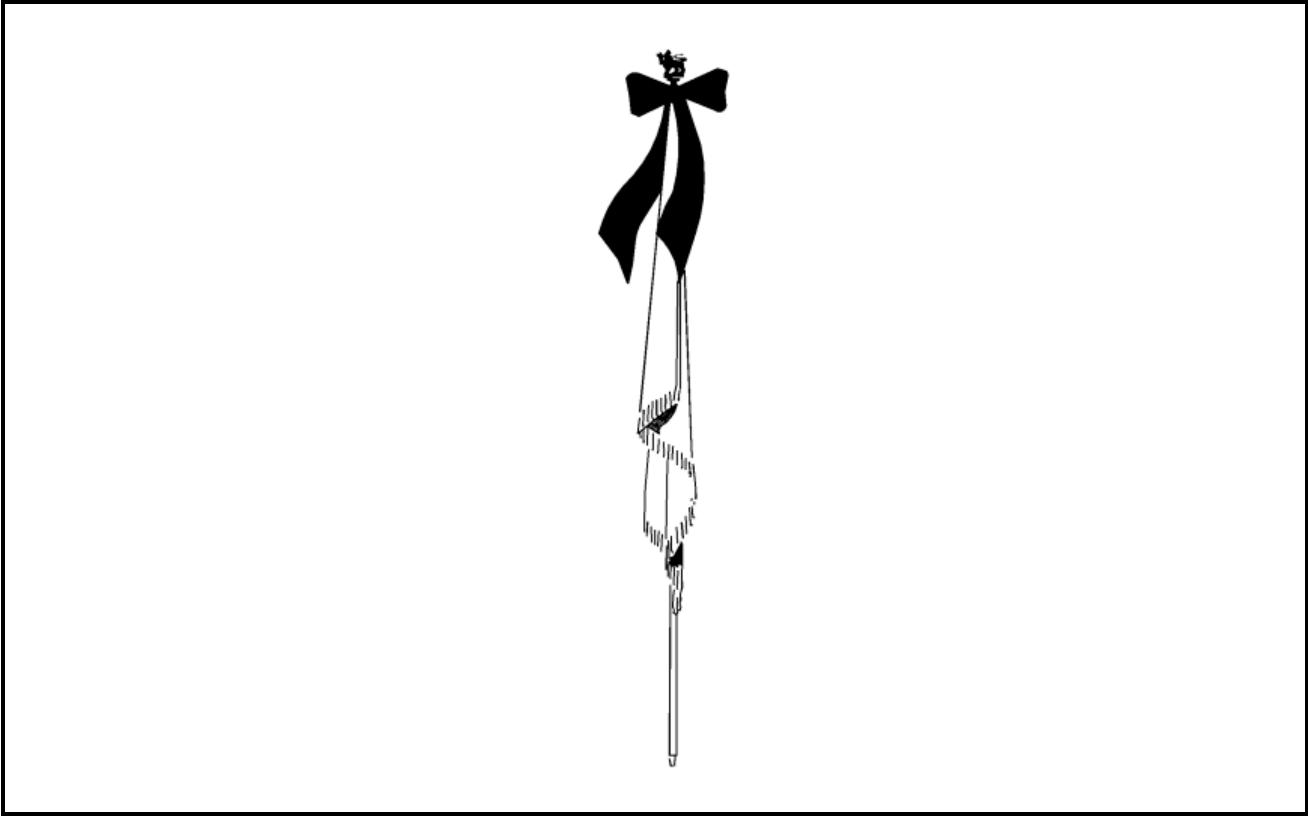

Figure 8-1- 1 Draping the Colour

SECTION 2

THE COLOUR PARTY

COMPOSITION OF A COLOUR PARTY

1. The composition of a Colour Party carrying one Colour (Figure 8-2-1) shall be:
 - a. Colour Officer – one junior officer (a Guidon is carried by a master warrant officer); and
 - b. Colour Escorts – two sergeants (or below, if necessary).
2. The composition of a Colour party carrying two Colours (Figure 8-2-2) shall be:
 - a. Colour officers – two junior officers; and
 - b. Colour Escorts – one master warrant officer or warrant officer, and two sergeants (or below, if necessary).
3. Colour parties are attended by Colour Orderly (corporal, drummer or private) for each Colour carried. Orderlies (not integral to the Colour Party or escort) usually march in supernumerary ranks of near (parade formations) sub-units until needed to attend the Colours, or wait off parade as required. See paragraph 11.
4. When a stand of Colours is carried, the Queen's Colour occupies the position of honour, i.e., on the right of the Colour party (on the left from the spectators point of view).

NOTE;

In RMC the composition of a **colour party** shall be all cadet officers.

COMPOSITION OF A FLAG PARTY

5. When the National Flag, Canadian Armed Forces (CAF) Ensign or command flags are carried on parade, they shall normally be carried by senior non-commissioned officers.
6. Normally, the National Flag has no escort. It may be given an armed escort if the troops on parade are armed. When paraded at multinational sporting and cultural events where other nations have an armed escort in their flag party, the composition of the Canadian flag party shall include an armed escort.
7. The CAF Ensign and command flags by themselves are not entitled to, and shall not be attended by, an armed escort. They may have such an escort when paraded in company with the National Flag if it has an armed escort.
8. When a flag party carries the National Flag and either the CAF Ensign or a command flag, the National Flag occupies the position of honour on the right (on the left from the spectators point of view).

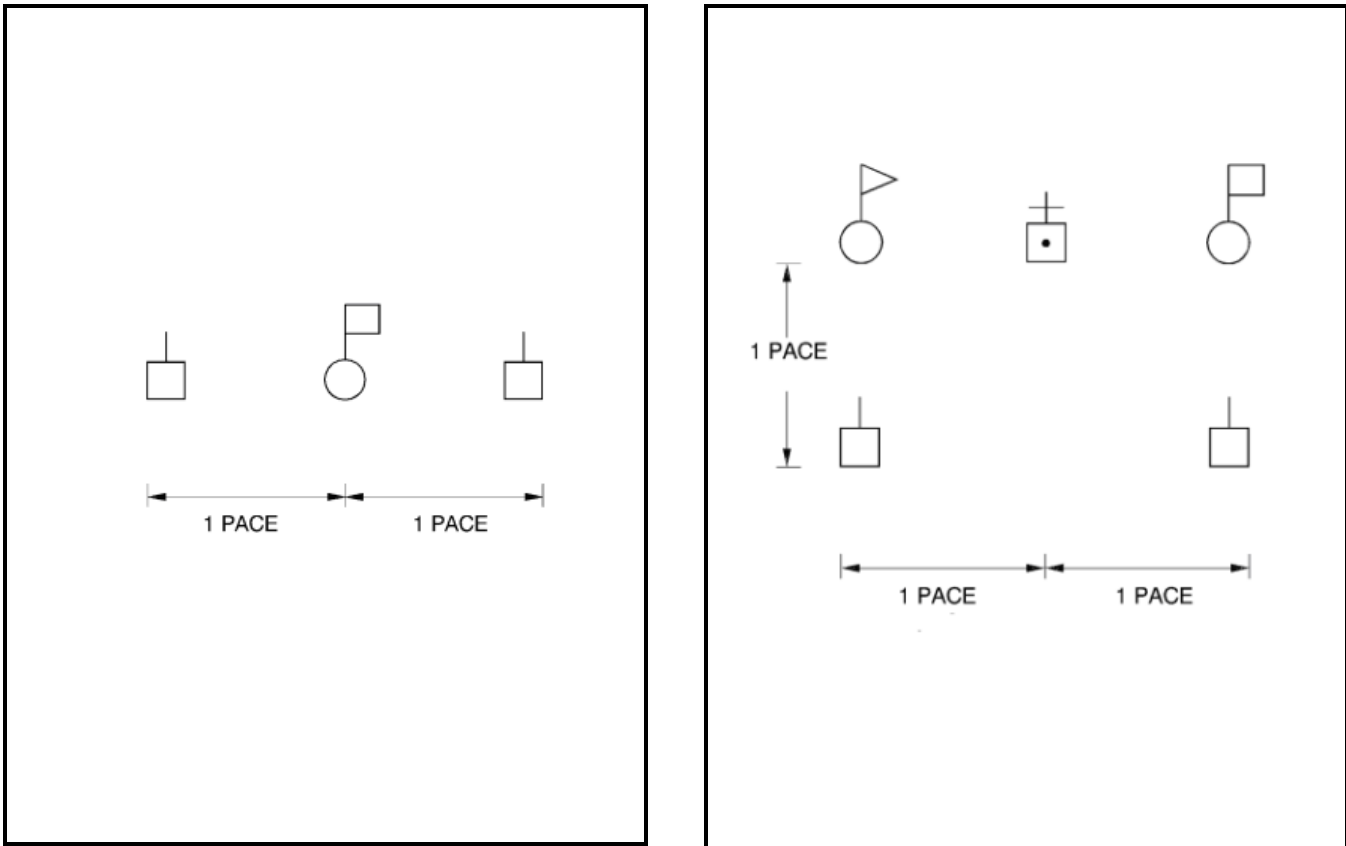

Figure 8-2- 1 Colour Party for One Colour

DUTIES

9. **Colour Officers (master warrant officer for Guidons).** Colour officers are appointed to carry, handle and protect the Colours.

10. **Colour Escort.** The mission of Colour escorts is to safeguard the Colours. Once they have taken up their duty, they remain with the Colour, or with any armed “escort to the Colour”, until it is safely lodged again. With an “escort to the Colour”, they occupy supernumerary positions until called upon to resume their close escort duties. When Colours are ordered to take post in review order, the escorts shall stand fast.

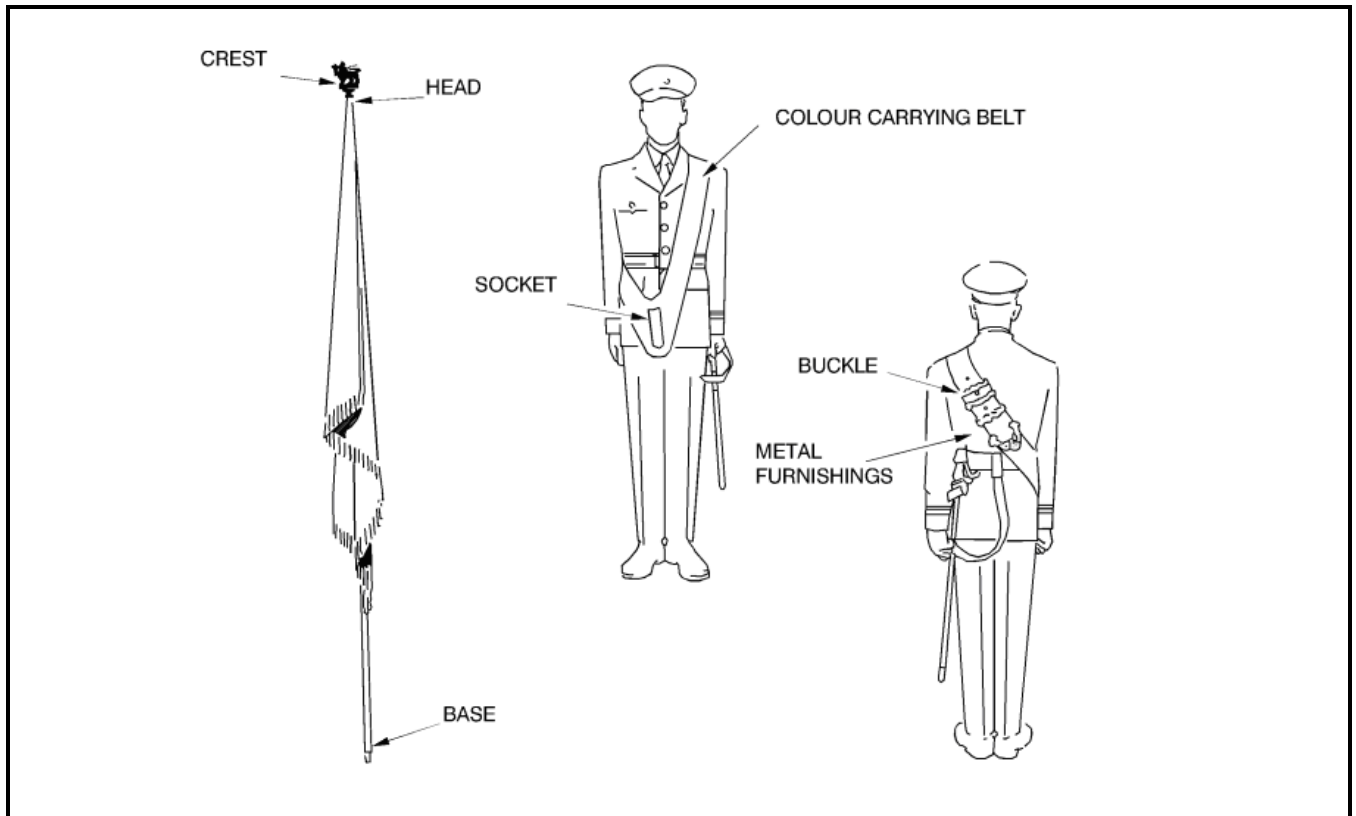

Figure 8-2- 2 Details of the Colour Pike and Belt

11. **Colour Orderlies.** When Colours are to be moved cased to a ceremonial parade, a Colour orderly shall be designated for each to assist the Colour officer and take charge of the cases during the parade. In units with a corps of drums, a drummer or bugler is traditionally given this responsibility, with the drum major assisting the adjutant with ensuring that Colours and Colour belts are ready for parades. Since a drummer or bugler with Colour orderly duties is precluded from playing an instrument, any other service member may be selected in lieu.

ARMS AND EQUIPMENT

12. The details of the Colour pike and belt are shown in Figure 8-2-3.
13. The Colour bearer wears the Colour belt over the left shoulder.
14. The Colour officer (or master warrant officer in the case of armoured regiments) shall be armed with a sword or a pistol.
15. The Colour escort shall be armed with bayonets fixed, the points of which may be covered with short sheathes, in order to avoid tearing the Colours.
16. Colour Party members when in charge of Colours do not remove headdress, nor do they unfix bayonets or remove swords (see Chapter 2, paragraph 23.)

SECTION 3

COLOUR DRILL

GENERAL

1. Colour drill shall be executed with a standard pause between movements in a similar manner to rifle drill.
2. A cased Colour shall be held in the order position at the halt and carried in the slope position on the march. A cased Colour is never held at the carry.
3. An uncased Colour is never sloped at the halt; it shall be at the carry or the order, according to whether arms are at the shoulder or the order.
4. On the march, an uncased Colour always shall be carried at the slope, except when on the review parade ground or when paying compliments. Then, it shall be at the carry.
5. During an inspection of personnel on parade the uncased Colour shall be at the carry.

POSITION OF THE ORDER

6. At the order (Figure 8-3-1):
 - a. The Colour bearer is at attention.
 - b. The pike is held vertical with the right hand, at the right side. The base of the pike is on the ground at the right side of the right foot, in line with the toe of the shoe.
 - c. The pike and Colour are held with an all-round grasp of the right hand, back of the hand outwards, at the point of the pike where the lowest corner of the Colour reaches.
 - d. The Colour shall hang naturally down the pike and shall not be stretched taut.
 - e. The right elbow is at the side.
 - f. The right wrist is directly in rear of the pike.
 - g. A cased Colour is held similarly except that the case is grasped in the right hand.

STAND AT EASE FROM THE ORDER

7. On the command STAND AT – EASE:
 - a. move the left foot in the normal manner (Figure 8-3-2); and
 - b. keep the Colour and pike unmoved in the same position as described for the order.

STAND EASY FROM STAND AT EASE

8. On the command STAND – EASY:
 - a. the Colour and pike remain in the same position;
 - b. the left arm is kept to the side; and

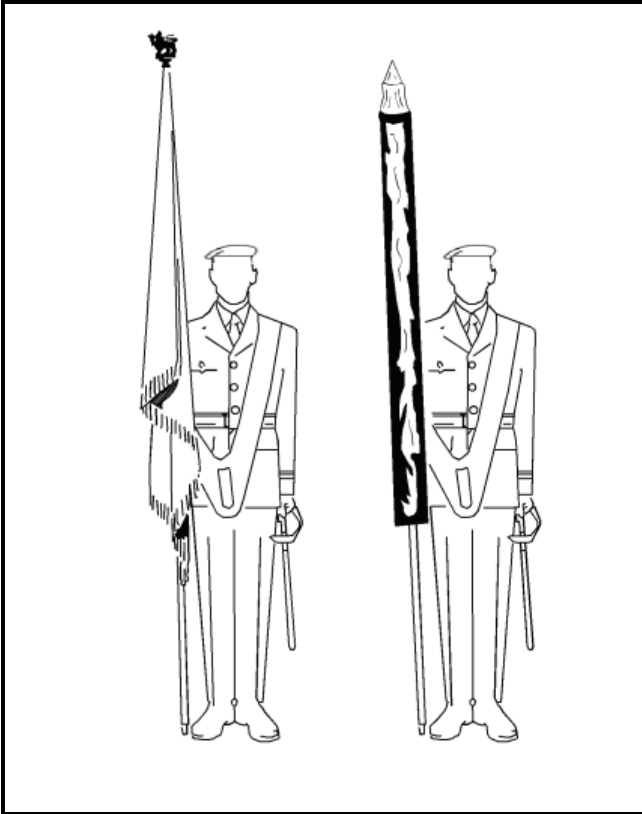

Figure 8-3-1 Position of the Order (uncased and cased)

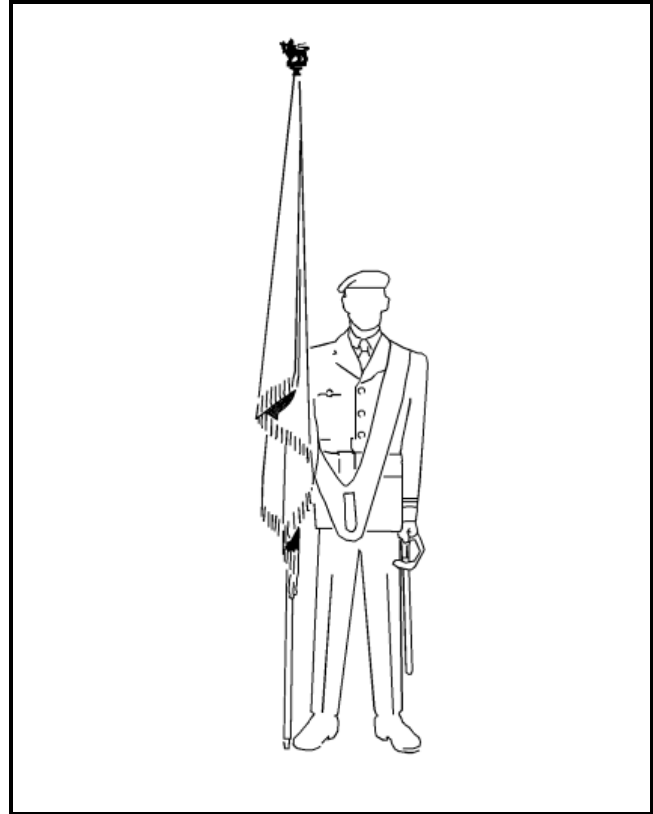

Figure 8-3-2 Stand at Ease

- c. the body is relaxed, but the feet and Colour are not moved.

9. The stand at ease position shall be resumed on the cautionary command SQUAD (GUARD) (etc.). The Colour Party never stands easy while in charge of Colours

10. DELETED

ORDER FROM STAND AT EASE

- 11. On the command ATTENTION, move the left foot in the normal manner.

CARRY FROM THE ORDER

- 12. On the command CARRY COLOUR(S) BY NUMBERS, SQUAD – ONE;
 - a. with the right hand, raise the Colour to a vertical position in front of the centre of the body, keeping the base of the pike just clear of the socket, and the right forearm alongside the pike (Figure 8-3-3); and
 - b. simultaneously, bring the left hand to the socket and guide the pike into the socket.
- 13. On the command SQUAD – TWO:
 - a. bring the left hand to the position of the order;
 - b. simultaneously raise the right forearm parallel to the ground; thus

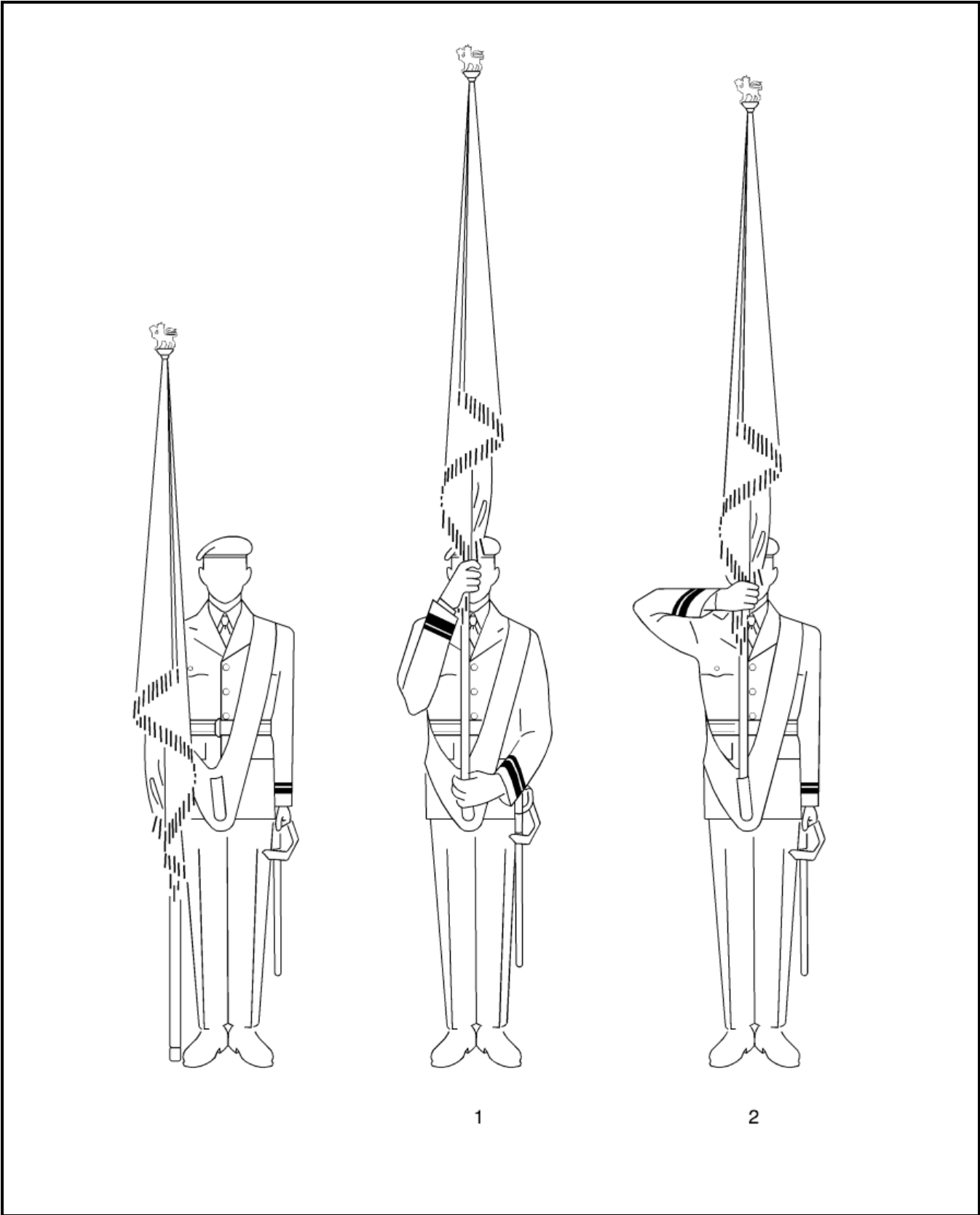

Figure 8-3-3 Carry from the Order

- c. on completion of the movement:
 - (1) the right hand is opposite the mouth,
 - (2) the right forearm is parallel to the ground at right angles to the pike,
 - (3) the wrist of the right arm is straight,
 - (4) the back of the hand is outwards, and
 - (5) the head and eyes are facing the front.

14. On the command CARRY – COLOUR, the two movements are combined. A standard pause shall be observed between the movements.

15. When arms are carried on a parade and the parade is given the command SHOULDER – ARMS, the Colour officer shall carry the Colour in time with the rifle movements.

ORDER FROM THE CARRY

16. On the command ORDER COLOUR(S) BY NUMBERS, SQUAD – ONE:

- a. with the right hand raise the pike clear of the socket, bringing the right forearm from the horizontal position to a vertical position alongside the pike (Figure 8-3-4); and
- b. simultaneously, bring the left hand to the socket to steady the pike and belt.

17. On the command SQUAD – TWO:

- a. carry the Colour with the right hand to the position of the order;
- b. move the left hand across the body to steady the pike; thus
- c. on completion of the movement:

- (1) the back of the left hand shall be outwards,
- (2) the fingers of the left hand are extended and pointing to the right, and
- (3) the left forearm is parallel to the ground.

18. On the command SQUAD – THREE, cut the left hand to the side in the position of attention.

19. On the command ORDER – COLOUR, the three movements are combined. A standard pause shall be observed between the movements.

20. When arms are carried on a parade and the parade is given the command ORDER – ARMS, the Colour officer shall order the Colour in time with the rifle movements, unless the command is given just prior to an inspection, when the Colour officer shall remain at the carry.

SLOPE FROM THE CARRY

21. Colours are never held at the carry when cased. Colours are sloped only when on the march (cased or uncased). For the purposes of initial instruction, positions shall be taught at the halt. On the command SLOPE COLOUR(S) BY NUMBERS, SQUAD – ONE:

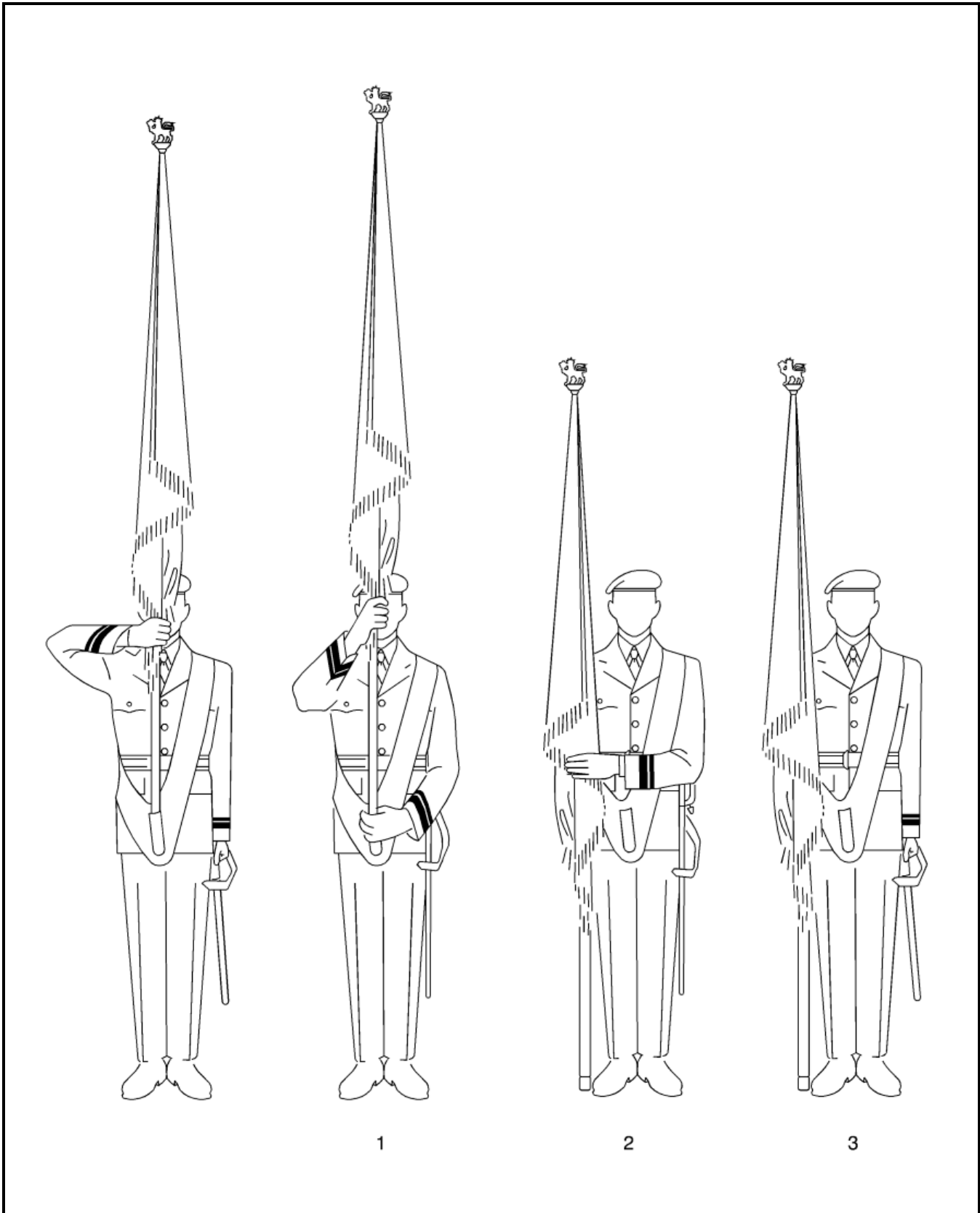

Figure 8-3- 4 Order from the Carry

- a. with the right hand raise the pike clear of the socket, bringing the right forearm from the horizontal position to a vertical position alongside the pike (Figure 8-3-5); and
 - b. simultaneously, bring the left hand to the socket to steady the pike and the belt.
22. On the command SQUAD – TWO:
- a. lower the Colour with the right hand to the right shoulder;
 - b. simultaneously, with the left hand grasp the pike above the right hand with an all-round grip, to steady the pike; thus
 - c. on completion of the movement:
 - (1) the Colour shall be at a 45 degree angle on the right shoulder,
 - (2) the elbow shall be close to the body,
 - (3) the right forearm should be in a comfortable position parallel to the ground,
 - (4) the Colour shall hang over and cover the right shoulder and arm, and
 - (5) the pike shall not show between the hand and the shoulder and shall be covered by the Colour.
23. On the command SQUAD – THREE, cut the left hand to the side assuming the position of the order.
24. On the command SLOPE – COLOUR, the three movements are combined. A standard pause shall be observed between the movements.
25. Upon departing the review parade ground or after paying compliments elsewhere, an uncased Colour normally should be returned to the slope in the following manner:
- a. On the command QUICK – MARCH, the Colour officer shall slope the Colour from the carry, executing the first movement on the first pace with the left foot and the remaining movements on successive paces with the left foot.
 - b. When the senior Colour officer gives the command SLOPE – COLOUR, after paying compliments on other than a review parade ground, the command is given on the left foot and the movements executed as above. When only one Colour is carried, the Colour officer shall carry out the movements without word of command.

SLOPE FROM THE ORDER (CASED COLOUR)

26. On the command SLOPE COLOUR(S) BY NUMBERS, SQUAD – ONE:
- a. with the right hand raise the pike clear of the ground and place it on the right shoulder (Figure 8-3-6); and
 - b. simultaneously, with the left hand grasp the pike above the right hand with an all-round grip, to steady the pike.
27. On the command SQUAD – TWO, cut the left hand smartly to the side, assuming the position of attention.
28. On the command SLOPE – COLOUR, both movements are combined, with a standard pause between movements. On the completion of the drill the Colour shall be at a 45 degree angle on the right shoulder, the right elbow close to the body and the right forearm in a comfortable position parallel to the ground.

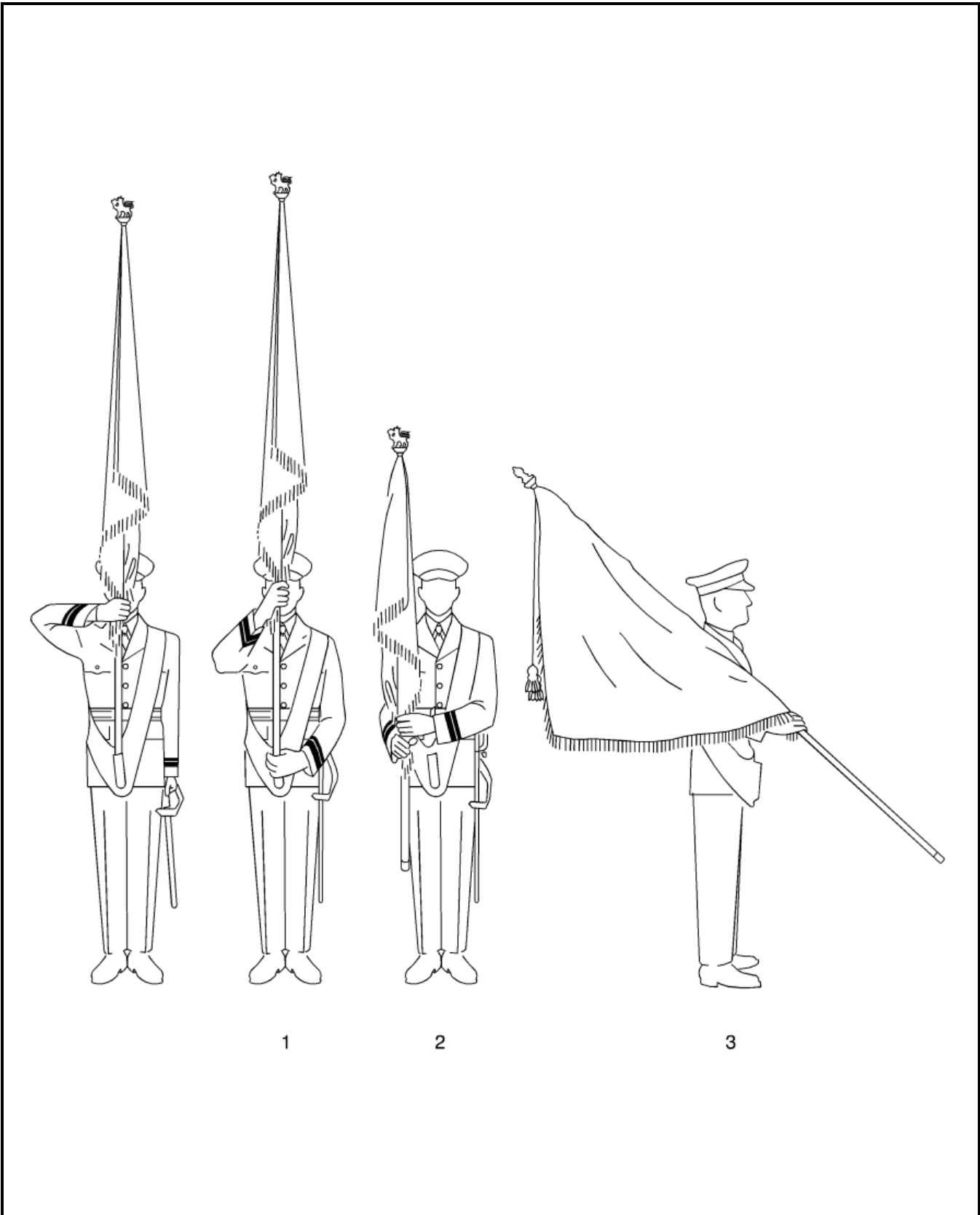

Figure 8-3- 5 Slope from the Carry

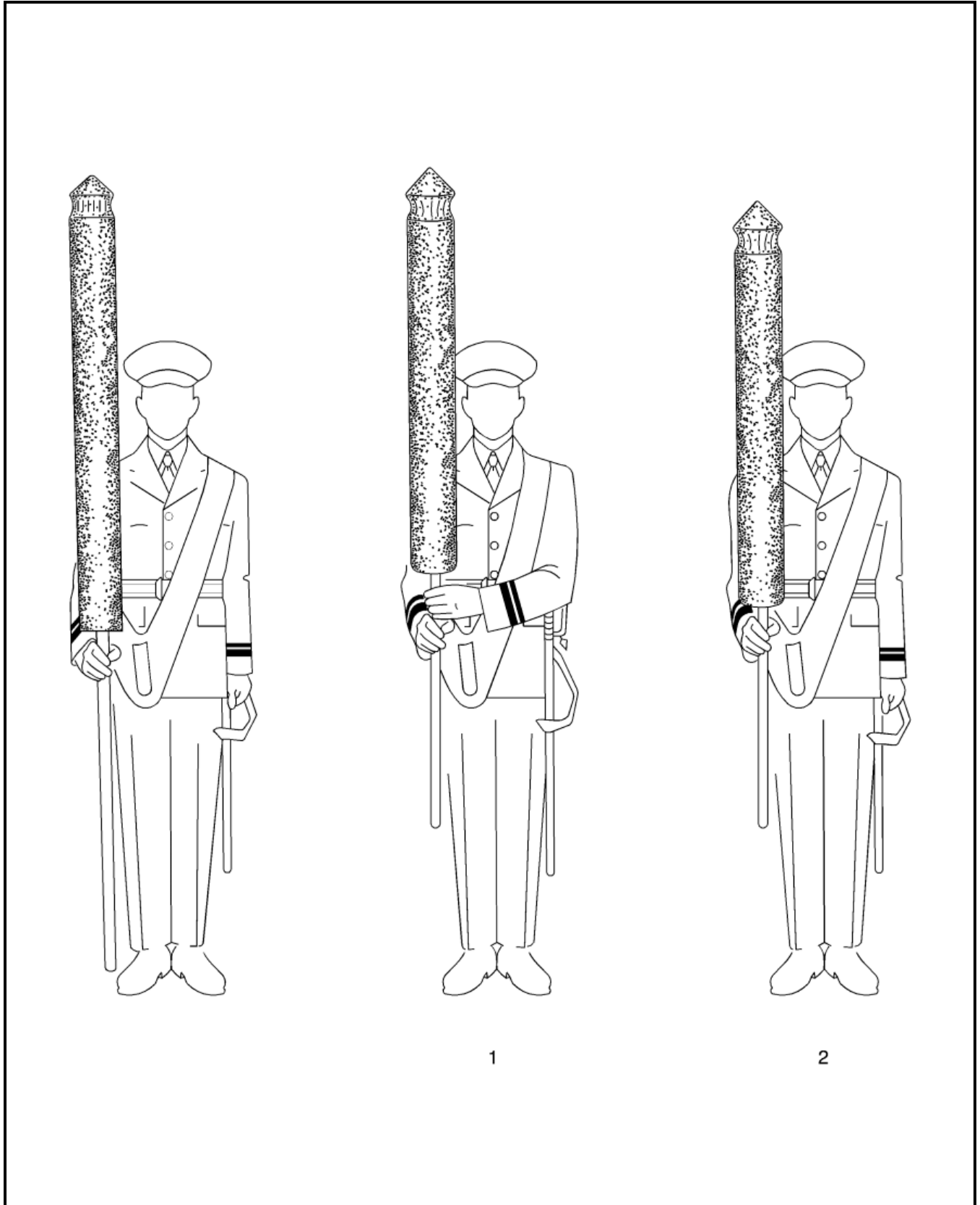

Figure 8-3- 6 Slope from the Order (Cased Colour)

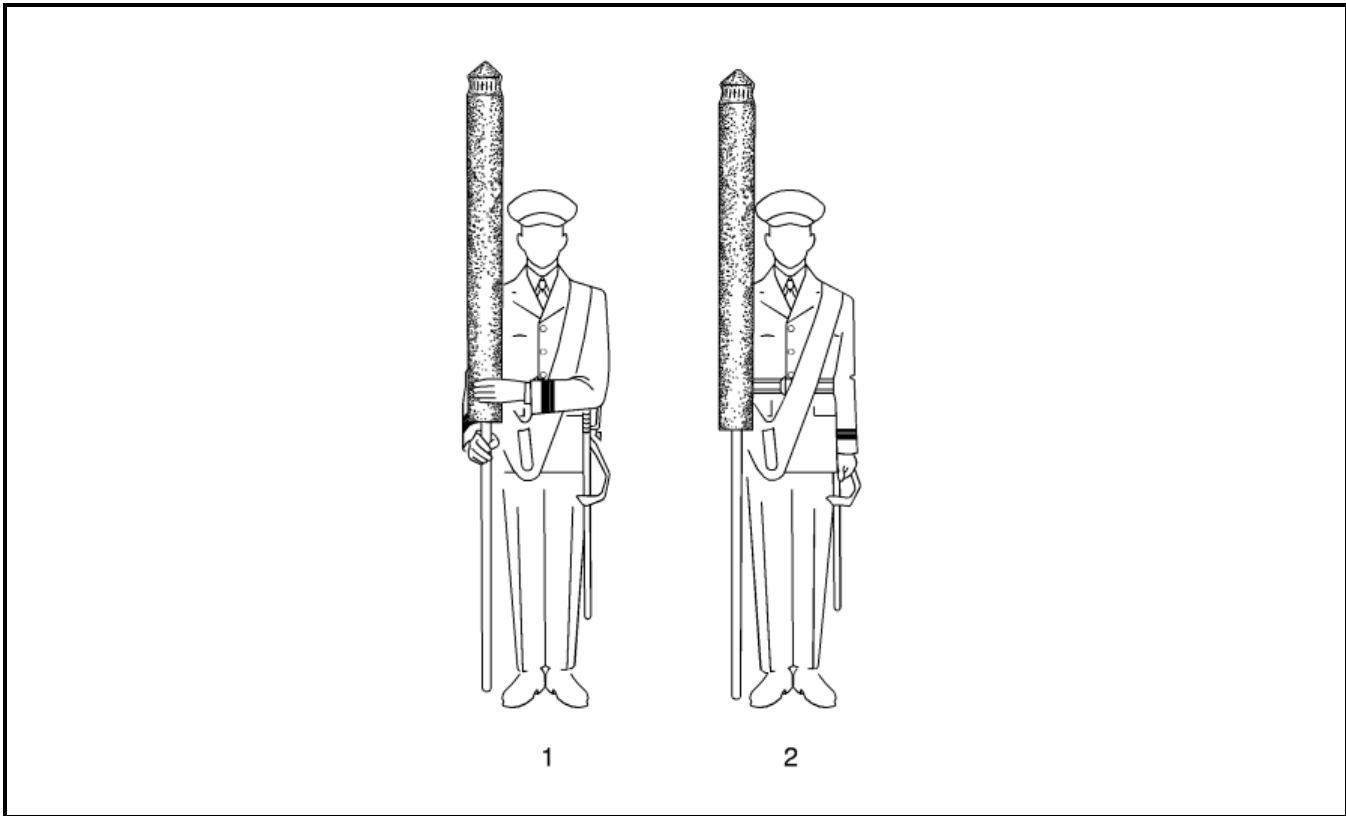

Figure 8-3-7 Order from the Slope (Cased Colour)

ORDER FROM THE SLOPE (CASED COLOUR)

29. On the command ORDER COLOUR(S) BY NUMBERS, SQUAD – ONE:
 - a. with the right hand lower the pike to the ground by straightening the right arm down the right side (Figure 8-3-7); and
 - b. simultaneously, bring the left arm smartly across the body, keeping the forearm parallel to the ground and steady the Colour by cupping the left hand around the case.
30. On the command SQUAD – TWO, cut the left arm smartly to the side, assuming the position of attention.
31. On the command ORDER – COLOUR, both movements are combined, with a standard pause between movements.

CHANGING THE COLOUR AT THE SLOPE

32. On the command CHANGE COLOUR(S) BY NUMBERS, SQUAD – ONE:
 - a. grasp the pike with the left hand above the right, in an all-around grip, back of the hand to the front, and thumb to the rear (Figure 8-3-8); and
 - b. keep the elbows close to the body.
33. On the command SQUAD – TWO:
 - a. carry the Colour, with the pike perpendicular, to a position 10 cm in front of the centre of the body; and
 - b. keep the elbows close to the body and both forearms parallel to the ground.

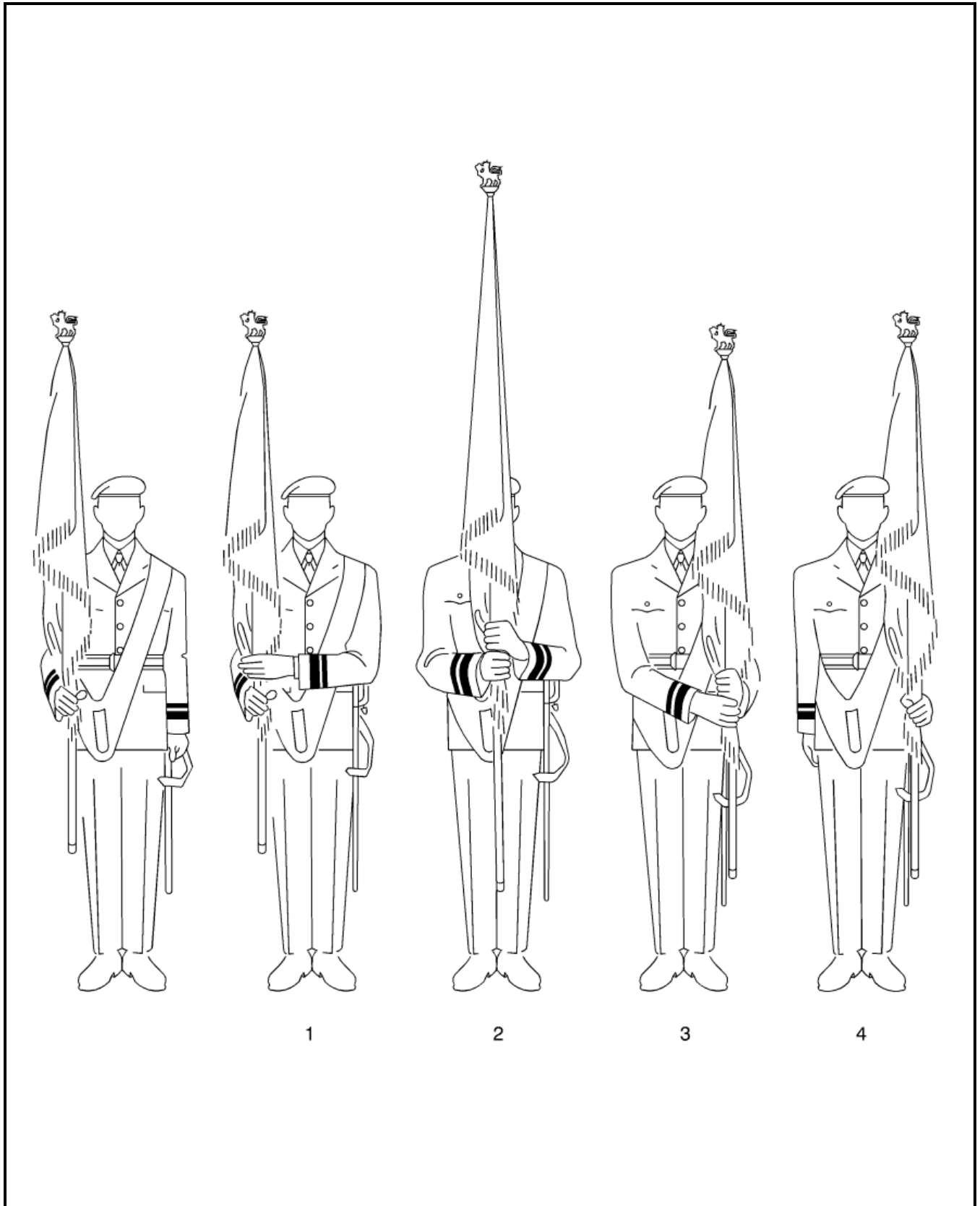

Figure 8-3- 8 Changing the Colour at the Slope

34. On the command SQUAD – THREE, place the Colour on the left shoulder, retaining the grip of both hands on the pike in a similar position to that described for the first movement above, except that the back of the right hand is now to the front.
35. On the command SQUAD – FOUR, cut the right hand to the side.
36. On the command CHANGE – COLOUR, combine the four movements, observing a standard pause between the movements.
37. To change Colour from the left to the right, the drill above is reversed.

CARRY FROM THE SLOPE

38. On the command CARRY COLOUR(S) BY NUMBERS, SQUAD – ONE:
 - a. raise the Colour off the right shoulder with the right hand to the perpendicular position of the carry from the order (Figure 8-3-9); and
 - b. simultaneously, bring the left hand to the socket to guide the base of the pike into the socket.
39. On the command SQUAD – TWO, cut the left hand to the side and assume the carry position.
40. On the command CARRY – COLOUR, the two movements are combined. A standard pause shall be observed between the movements.

LET FLY FROM THE CARRY

41. On the command LET FLY THE – COLOUR(S), maintaining the grip on the pike, release the Colour with a downward movement of the right hand (Figure 8-3-10). As the Colour is free, return the right hand to the previous position, in front of the mouth.
42. When arms are carried on parade and the order GENERAL SALUTE, PRESENT – ARMS is given, the Colour shall be let fly on the first movement of the present arms.
43. During the march past in quick time, on the command EYES – RIGHT, the Colour is let fly on the next left foot.
44. On the command EYES – FRONT, the Colour is caught as detailed in paragraph 45.

CATCHING THE COLOUR FROM THE LET FLY

45. On the command CATCH THE COLOUR(S) BY NUMBERS, SQUAD – ONE:
 - a. grasp the Colour with the left hand and bring it in to the pike (Figure 8-3-11); and
 - b. simultaneously, grasp the corner of the Colour with the right hand, back of the hand outwards, at the point of the pike where the lowest corner of the Colour reached.
46. On the command SQUAD – TWO, cut the left hand to the side to the position of attention and raise the right forearm to the horizontal position.
47. On the command CATCH THE – COLOUR, the two movements are combined. A standard pause shall be observed between the movements.

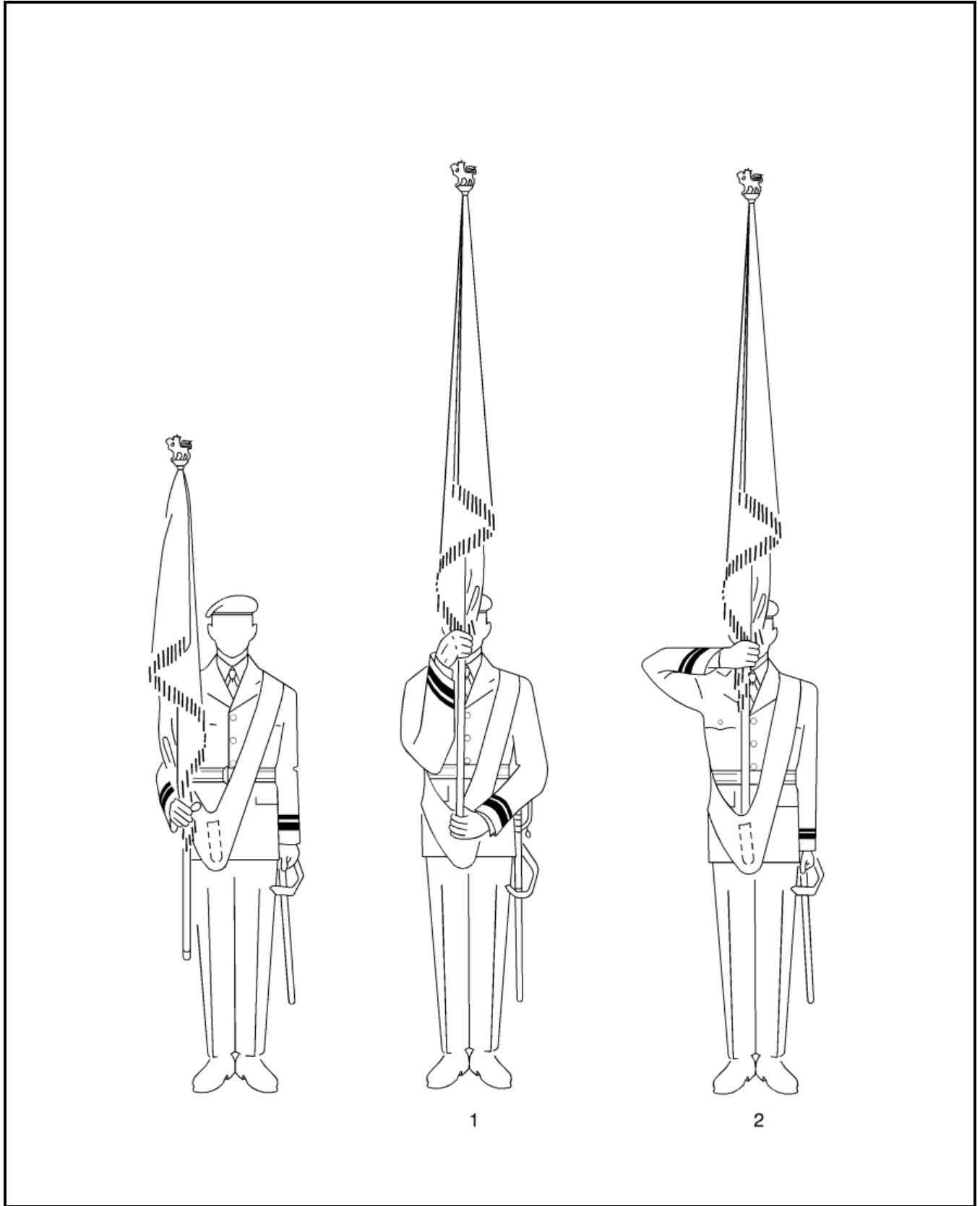

Figure 8-3- 9 Carry from the Slope

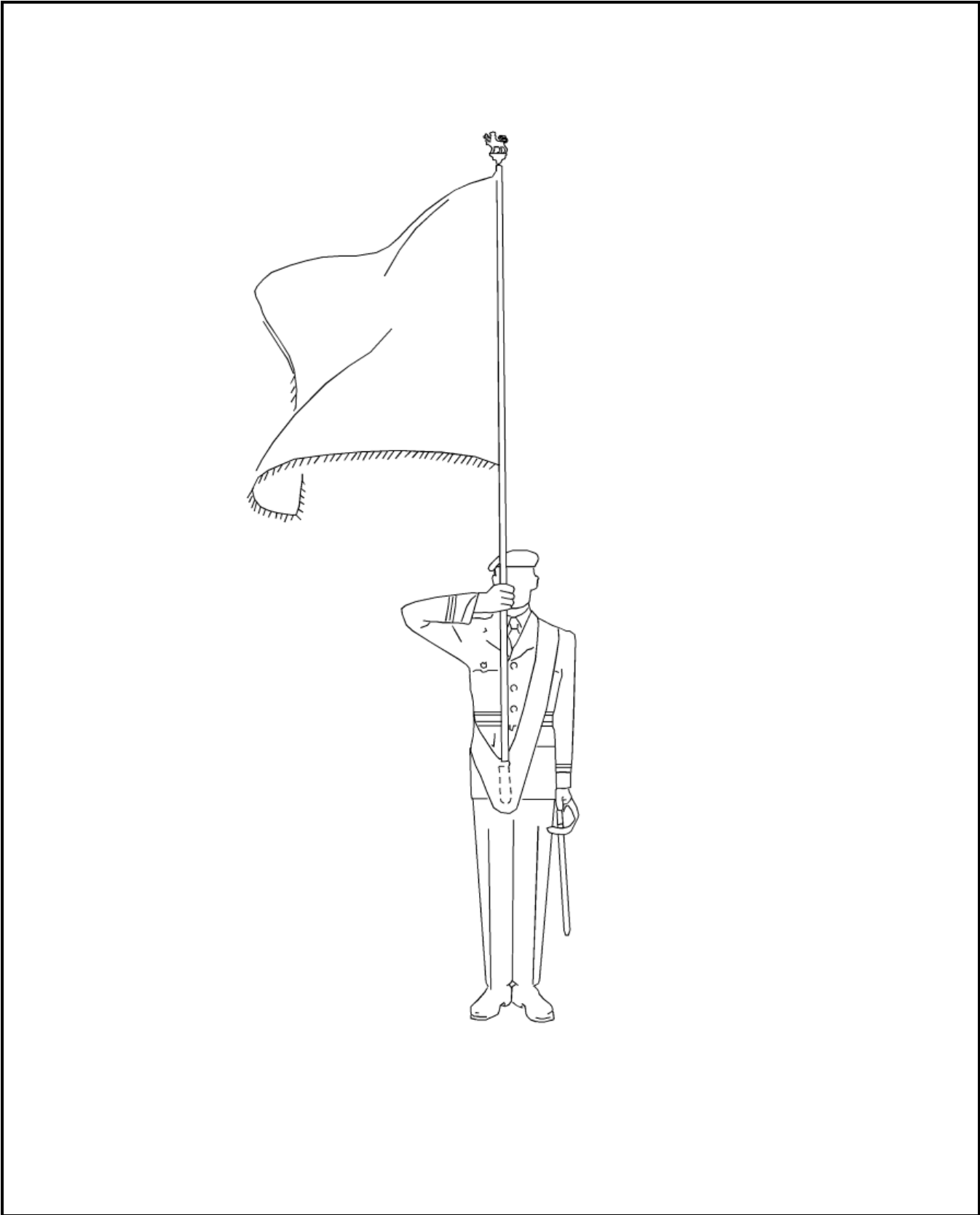

Figure 8-3- 10 Let Fly from the Carry

48. Depending on the wind direction, the Colour may be grasped with the right hand after securing the pike in the left hand. If, because of wind strength, the Colour cannot be caught, the Colour shall be brought to the position of the order, the Colour secured and returned to the carry. The same drill is executed while marching.

49. When arms are carried on parade and the parade is ordered to shoulder arms from the present, the Colour officer shall carry out the movements in time with the rifle movements.

DIP FROM THE CARRY AT THE HALT

50. On the command DIP THE COLOUR(S) BY NUMBERS, SQUAD – ONE:

- a. releasing the Colour from the pike, raise the pike to the full extent of the right arm (Figure 8-3-12); and
- b. simultaneously, bring the left hand across the body and grasp the socket to steady the Colour belt.

51. On the command SQUAD – TWO:

- a. maintaining control of the base of the pike with the right armpit, carry the pike well out to the right with the right hand and lower it with a sweeping motion to a position in front of the right foot;
- b. simultaneously, cut the left hand to the side to the position of attention; thus
- c. on completion of the movement:
 - (1) the pikehead shall be just clear of the ground,
 - (2) the Colour shall be spread on the ground to the right of the pike (see paragraph 54), and
 - (3) the pike shall be held under the right armpit, the back of the right hand towards the ground.

52. On the command DIP – COLOUR, the two movements are combined. A standard pause shall be observed between the movements.

53. If the ground is wet or muddy, the pikehead shall be 5 cm above the ground. The Colour shall be held in the left hand to prevent it from being soiled (Figure 8-3-13).

54. If a strong wind is blowing from the right, the pike shall be carried with the right hand well to the left, and then lowered with a sweeping motion to the position of the dip. The Colour shall be spread to the left of the pike.

55. When arms are carried on parade and the order ROYAL SALUTE, PRESENT – ARMS is given, the Colour officer shall coordinate the movements of the dip with the rifle movements, the Colour spread on the ground coincident with final rifle movement.

CARRY FROM THE DIP AT THE HALT

56. On the command CARRY COLOUR(S) BY NUMBERS, SQUAD – ONE:

- a. raise the Colour with the right hand, to the perpendicular position of the carry; and
- b. simultaneously, bring the left hand to the socket to guide the base of the pike into the socket.

57. On the command SQUAD – TWO:

- a. grasp the Colour with the left hand and bring it in to the pike; and
- b. simultaneously, grasp the corner of the Colour with the right hand as for the carry.

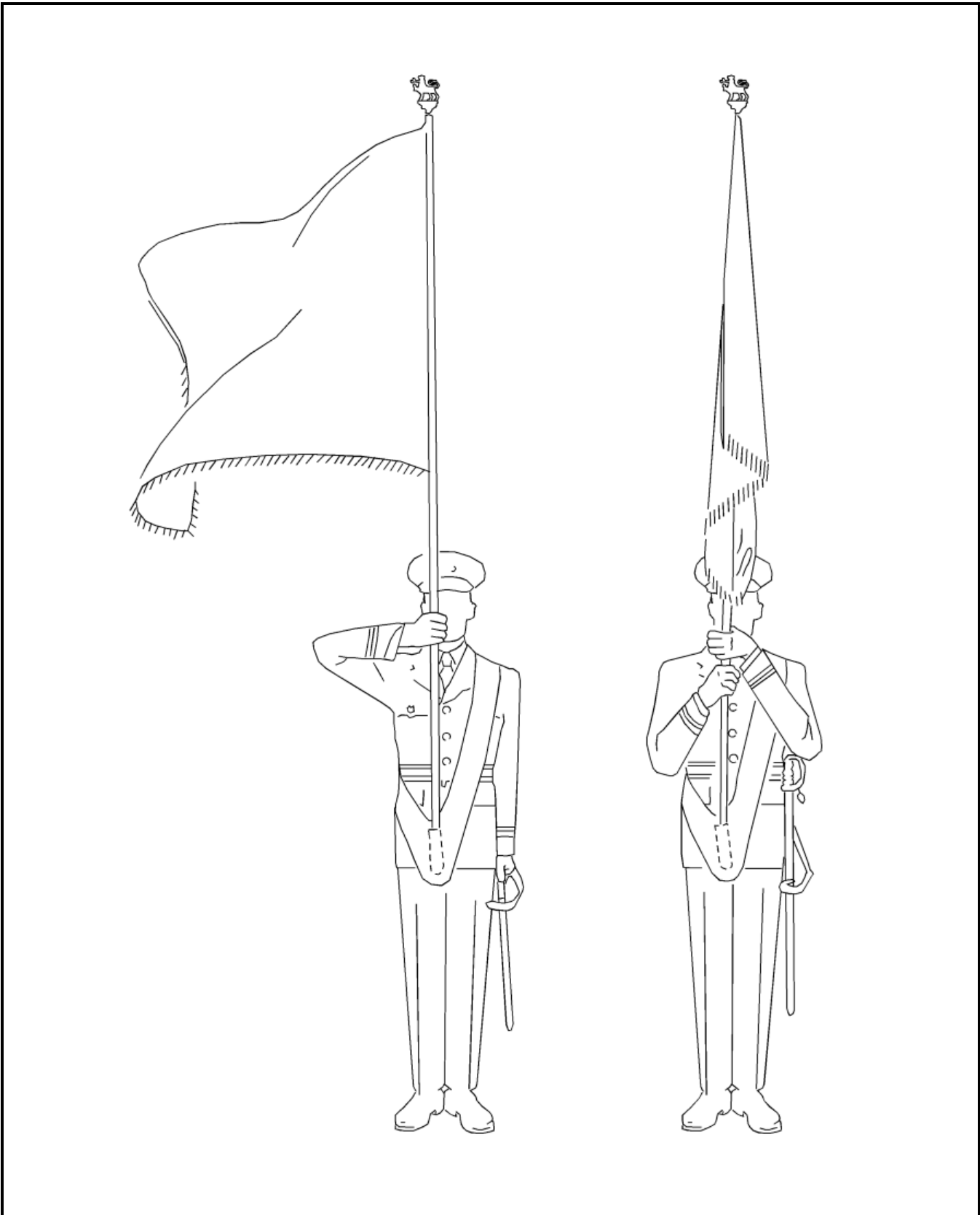

Figure 8-3- 11 Catching the Colour from the Let Fly

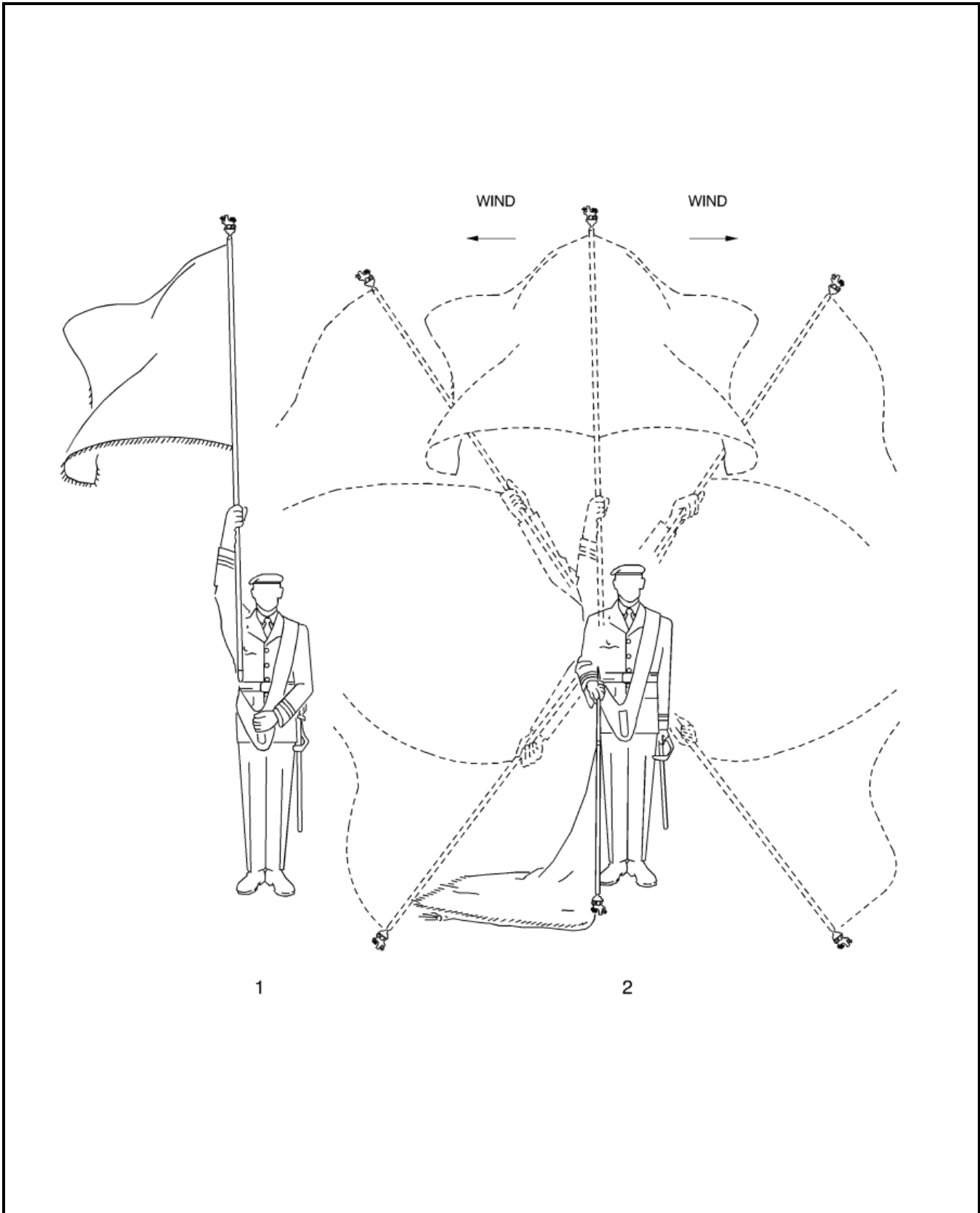

Figure 8-3- 12 Dip from the Carry at the Halt

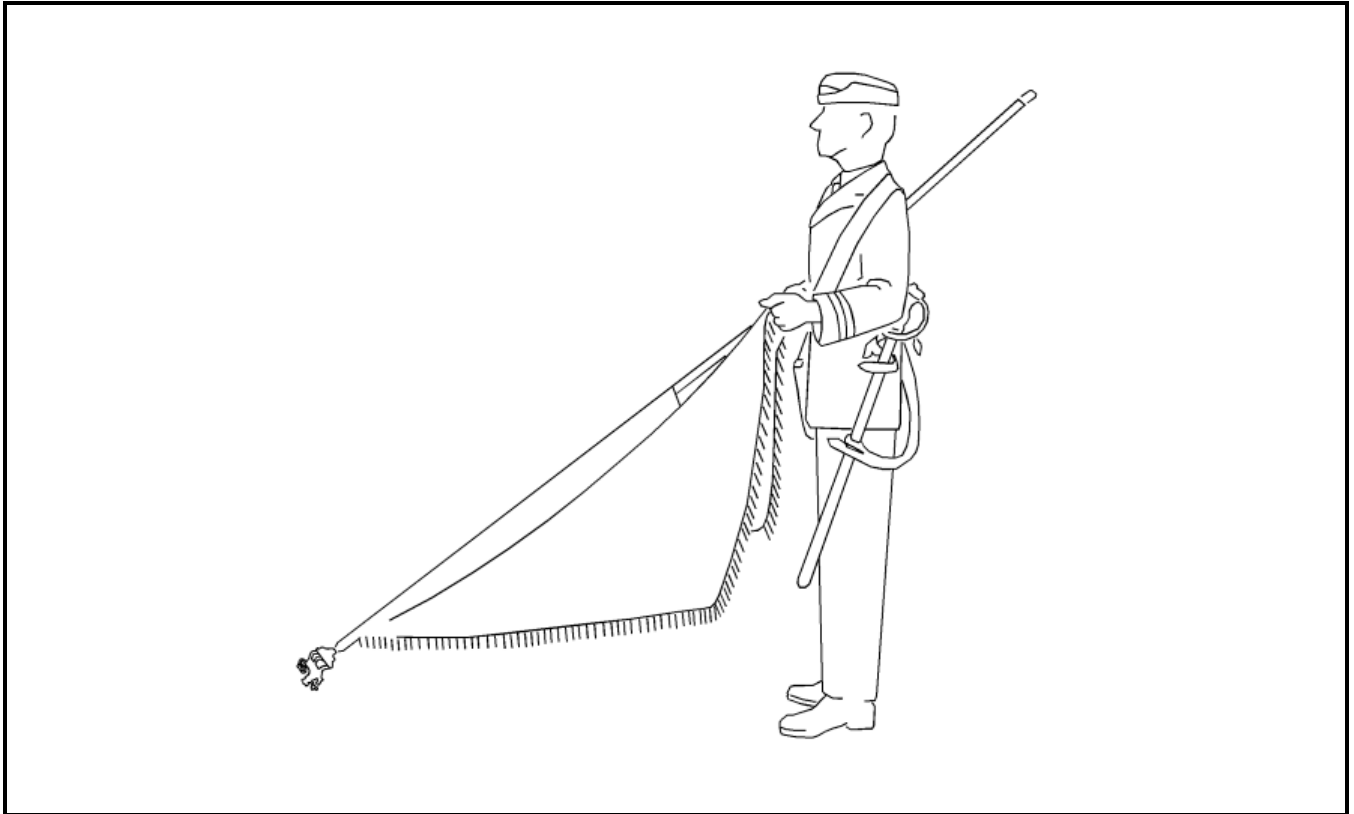

Figure 8-3- 13 Dip Position – Wet Ground

58. On the command SQUAD – THREE, cut the left hand to the side and assume the position of the carry.
59. On the command CARRY – COLOUR, the three movements are combined. A standard pause shall be observed between the movements.
60. When arms are carried on parade and the parade is ordered, SHOULDER – ARMS, following the command ROYAL SALUTE, PRESENT – ARMS, the Colour officer shall execute the first two movements of the carry from the dip, at the halt, in time with the two movements of the shoulder arms.

DIP FROM THE CARRY ON THE SLOW MARCH (CONSACRETED COLOURS ONLY)

61. The dip is only executed on the march in slow time.
62. On the command EYES – RIGHT given as the left foot is forward and on the ground, the Colour shall be let fly on the next pace with the left foot (Figure 8-3-14).
63. On the following pace with the left foot:
 - a. grasp the socket with the left hand; and
 - b. raise the pike clear of the socket with the right hand.
64. On the next pace with the left foot:
 - a. maintaining control of the base of the pike under the right armpit, move the Colour in a sweeping motion to the right and lower the pike to a horizontal position directly in front; and
 - b. simultaneously, cut the left hand to the side.

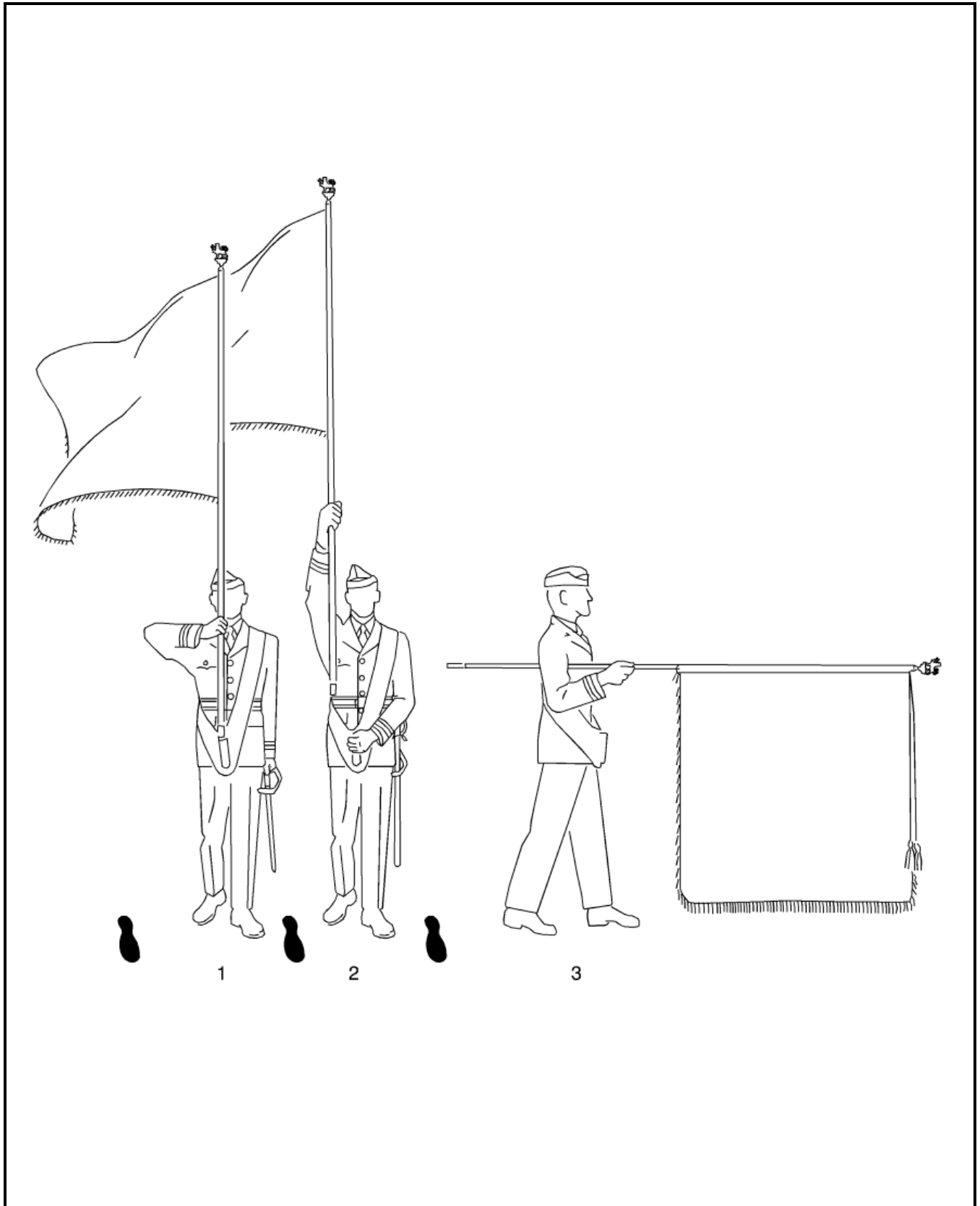

Figure 8-3- 14 Dip from the Carry on the March

65. On completion of the movement:
- a. the back of the right hand shall be towards the ground;
 - b. the right elbow shall be close to the side;
 - c. the Colour shall hang straight down;
 - d. the left arm shall be straight at the side; and
 - e. the head and eyes shall be straight to the front.

CARRY FROM THE DIP ON THE MARCH

66. On the command EYES – FRONT, on the next pace with the left foot:
- a. raise the Colour with the right hand, to the perpendicular position of the carry; and
 - b. simultaneously, bring the left hand to the socket to guide the base of the pike into the socket.
67. On the following pace with the left foot, the Colour shall be caught with the left hand, and the corner of the Colour shall be grasped with the right hand.
68. On the next pace with the left foot, cut the left hand to the side.
69. If the wind is strong, the Colour may be secured as noted in paragraph 45.

SECTION 4

REMOVING AND LODGING THE COLOURS

GENERAL

1. When the Colours are removed and returned to the place where they are lodged, they shall be escorted by a Colour party.

REMOVING THE COLOURS

2. The procedure for removing Colours from the mess or other lodging shall be:
 - a. the Colour bearers shall collect the Colours from their place of safekeeping, case them as necessary (see paragraph 3) within the lodging's shelter and wait for the arrival of the escort;
 - b. the escort for the Colour shall be marched to the lodging, halted facing the place and bayonets shall be fixed;
 - c. the Colour bearers shall leave the lodging and fall in, the Queen's Colour on the right; and
 - d. under command of the senior Colour officer, the Colour party shall march to the parade ground, Colours cased at the slope.
3. If the lodging is next to or close by the parade ground, the Colours may be fallen in uncased. In this event:
 - a. the senior member of the escort shall order PRESENT – ARMS as the Colours exit the lodging; and
 - b. the senior Colour officer shall order SHOULDER – ARMS after the Colours have been fallen in.

LODGING THE COLOURS

4. After the completion of the parade, when the Colours have been marched off and cased, the senior Colour officer shall march the Colour party to the place where they are to be lodged, with the Colours at the slope. The Colour officers shall enter and return the Colours for safe-keeping.
5. If the lodging is next to or close by the parade ground, they may be returned uncased. In this event:
 - a. the senior Colour officer shall order the escort to PRESENT – ARMS; and
 - b. the Colour officers shall carry the Colours into the lodging and, after they are in the place, the senior member of the escort shall order SHOULDER – ARMS.
6. Under the command of the senior member of the Colour escort, the escort shall then unfix bayonets and if not requested to attend Colour Officers, shall directly march off to the dismissal area.

SECTION 5

CASING AND UNCASING THE COLOURS

CASING THE COLOURS

1. After being marched off parade, unless the place for lodging is close-by, the Colour party moves to the side of the parade ground and takes up a position facing the flank of the unit. The Colour orderlies fall in side by side, three paces to the left of the Colour party.
2. The Colour officers come to the order and the senior orders CASE, THE COLOUR(S).
3. On this command, the Colour orderlies move to a position four paces in front of and facing their respective Colour, halt, salute, take one pace forward and raise their left forearm parallel to the ground, cupping the left hand.
4. The Colour officers lower the pikes, directly forward, to a horizontal position, as for the last movement of the dip on the march, bringing the crests to rest in the orderlies, cupped left hands (Figure 8-5-1).
5. The Colour officers, with the left hand, and the orderlies, with the right hand, grasp the bottom corner of the Colour nearest to them and together fold the bottom edge of the Colour over the pike, ensuring that the fringe also hangs over the pike. The above procedure is executed three times, ensuring that there are no creases and that the Colours are neatly rolled along the top of the pike. As the Colour is folded, successive folds are held in place by the right thumb of the Colour officer and the left thumb of the orderly. The orderlies then wrap the tasselled cords around the Colours three times along their width. The Colour officers grasp the ends of the cords and the Colour in their left hand.
6. The orderlies remove the cases from their left forearms and carefully slide them over the Colours. As the cases are slid to the bottom of the Colours, the Colour officers, with their left hand, assist in pulling the cases fully over the Colours. The officers then tie the laces while the orderlies steady the horizontal pikes. When finished, Colour officers then cut their left arms sharply to the side.
7. When the cases are in place, the orderlies resume their original position, cupping the caps in their left hand, and, upon a signal from the Colour officers, give the pikes an upward thrust with the left hand, assisting the officers to return the Colours to the order position. The orderlies cut their left arms smartly to the side.

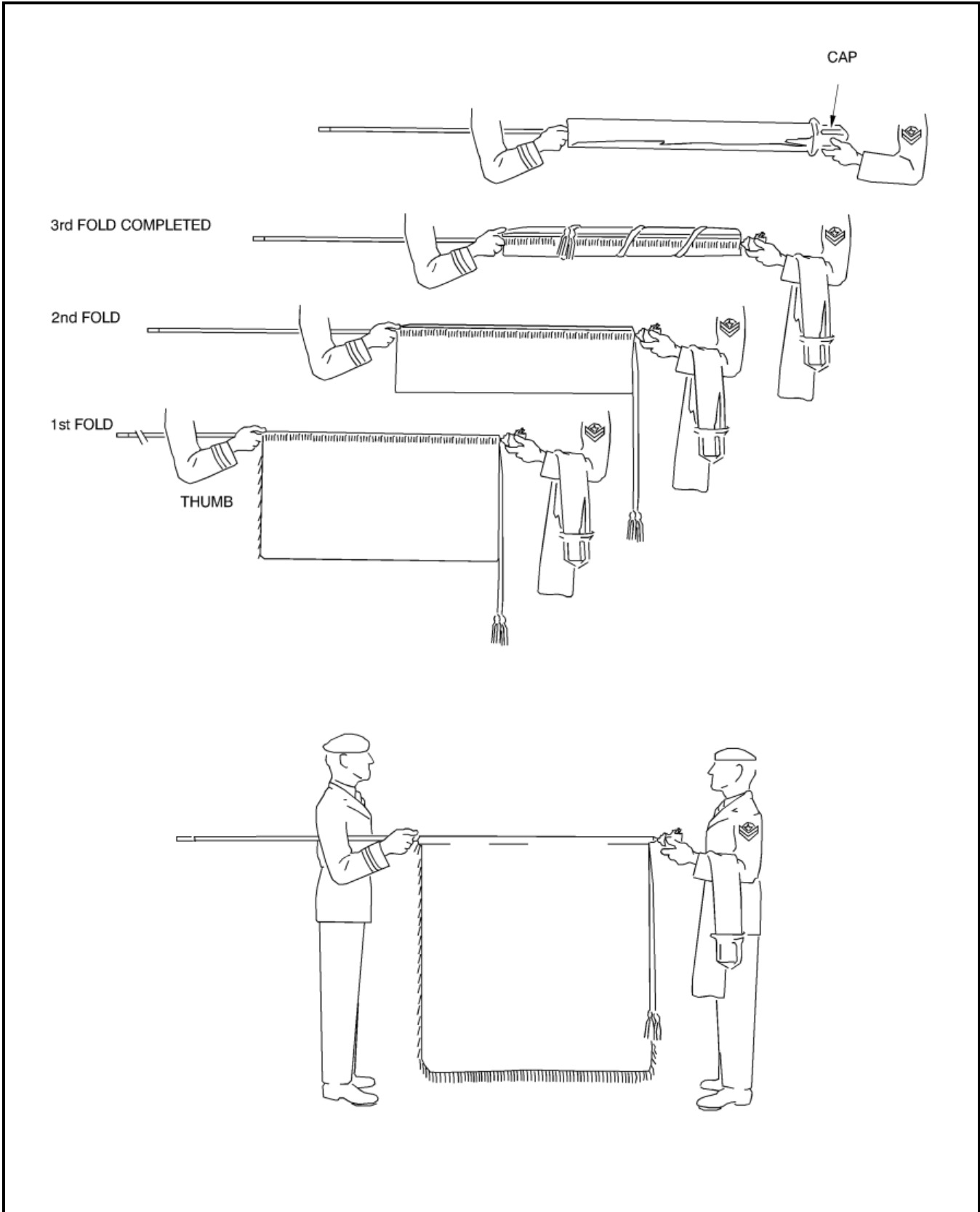

Figure 8-5- 1 Casing and Uncasing the Colours

8. The orderlies step back to their original position, salute, turn right and march off the parade ground.
9. The Colour party, under command of the senior Colour officer, returns the Colours to their lodging.

UNCASING THE COLOUR

10. On arrival at the parade ground, the Colour party positions itself on the nearest flank of the parade, the orderlies falling in three paces to the left of the Colour party.
11. The senior Colour officer, at the order position, commands UNCASE, THE COLOUR(S).
12. On this command, the Colour orderlies move to a position four paces in front of, and facing, their respective Colour. They halt, salute, take one pace forward and raise their left forearm parallel to the ground, cupping the left hand.
13. The Colour officers lower the pikes directly forward to a horizontal position, as for the last movement of the dip on the march. The caps are brought to rest in the cupped left hands of the orderlies.
14. The Colour officers untie the tapes of the case and grasp the Colours with their left hand inside the case. The orderlies carefully remove the cases and place them over their left forearm, the caps to the left.
15. The senior Colour officer shall then order COLOUR PARTY, TO THE COLOUR, PRESENT – ARMS.
16. The orderlies then unroll the cords, the Colour officers release the Colour and cut the left arms smartly to the side. The Colour orderlies then ensure that the Colours and cords hang correctly.
17. On a signal from the Colour officers, the orderlies give the pikes an upward thrust, assisting the officers to return the Colours to the order position. The orderlies then cut their arms smartly to the side.
18. The Colour officers dress the Colours to ensure that they are evenly distributed on both sides of the pike. The orderlies assist if required.
19. The orderlies step back to their original position, salute, turn right and march off the parade ground to a pre-designated location.
20. The senior Colour officer then shall order COLOUR PARTY, SHOULDER – ARMS.

SECTION 6**MARCHING ON AND OFF THE COLOUR****MARCHING ON THE COLOUR**

1. Colours shall be held at the carry while being marched on and off parade.
2. On the command MARCH ON THE COLOUR(S), given by the parade commander, the following shall take place:
 - a. the senior Colour officer shall order the cautionary COLOUR PARTY;
 - b. the parade commander shall order TO THE COLOUR(S), PRESENT – ARMS; and
 - c. the senior Colour officer shall order BY THE RIGHT (CENTRE), QUICK – MARCH. If a band is on parade, it shall play appropriate music.
3. The Colour party shall march to its position by a series of forms and counter-marching (Figure 8-6-1). Upon halting in its parade position, the senior Colour officer orders COLOUR PARTY, TO THE COLOUR(S), PRESENT – ARMS.
4. Once the Colour escort is at the present, the parade commander orders SHOULDER – ARMS, and the parade, now including the Colour party, shoulders arms.
5. Until it is ordered off at the conclusion of the parade, the Colour party shall act normally on the parade commander's command, except in the following circumstances:
 - a. During an inspection, the Colour shall be held in the carry position.
 - b. When required to move to a flank independently, the Colour party shall do so under command of its senior Colour officer by executing forms at the halt or on the march.

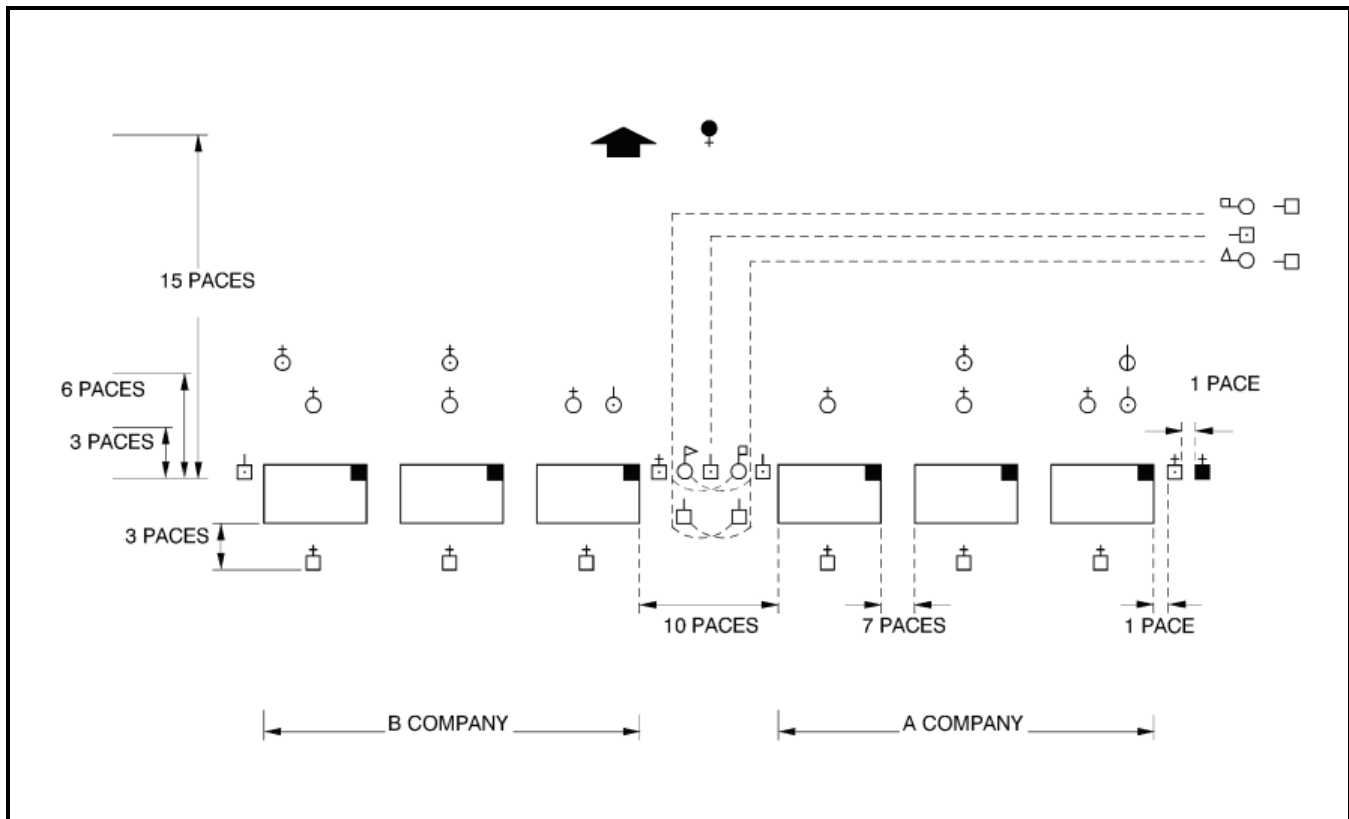

Figure 8-6-1 Marching on and off the Colour (Battalion in Line)

MARCHING OFF THE COLOUR

6. On the conclusion of the parade, the parade commander shall order MARCH OFF THE – COLOUR(S).
7. The senior Colour officer shall order the cautionary COLOUR PARTY.
8. The parade commander shall order TO THE COLOUR(S), PRESENT – ARMS.
9. The senior Colour officer shall order BY THE RIGHT (CENTRE), QUICK – MARCH. If a band is present, it shall play appropriate music.
10. The Colour party, by forming, shall march off the parade ground to the left or right flank (Figure 8-6-1).
11. While marching with the unit, the colour party shall conform to the movements of the parade (e.g. wheeling or forming)
12. When turning at the halt is required (e.g. for a march past in column of route), the Colour party shall change direction by executing a number of marking time paces (e.g. 20) and manoeuvring into position.
13. It is permissible to march on/off the Colours by wheeling in lieu of forms, if the circumstances exist. (e.g. the Colour Party is not trained to do forms in an exceptional manner). Forms being preferred.

SECTION 7

POSITIONS OF COLOURS ON PARADE

BATTALION PARADE

1. The Colours shall be positioned in the centre of the battalion as described below. If the battalion has an odd number of companies on parade, the Colours shall be positioned in the first interval between companies toward the honour side of the battalion's centre, i.e., to the right in line and mass, and to the front in column of companies.
2. **Battalion in Line.** The Colours shall be positioned between the two centre companies as follows:
 - a. **One Colour.** The Colour officer is positioned in line with the front rank and the escort in line with the rear rank.
 - b. **Two Colours.** The Colour officers and Colour warrant officer are positioned in line with the front rank and the sergeants in line with the rear rank (Figure 8-6-1).
3. **Battalion Retired.** If the battalion is ordered to retire, the Colour party will turn about, but will remain steady in its original alignment.
4. **Battalion in Column of Route/Column of Threes.** The Colours shall be positioned between the two centre companies as follows:
 - a. **One Colour.** The Colour officer covers off the centre file of the battalion and the Colour escorts cover off the flank files.
 - b. **Two Colours.** The Colour officers and the Colour escorts cover off the flank files of the battalion and the warrant officer covers off the centre file.
5. **Battalion in (Close) Column of Companies.** The Colour party shall be positioned between the front company and the centre company; when marching past, the following positioning will be observed:
 - a. **One Colour.** Alignment shall be with the supernumerary rank of the company in front.
 - b. **Two Colours.** The two sergeants shall take post by moving up on the right and left of the Colours respectively, the whole party being aligned with the supernumerary rank of the company in front (Figure 8-7-1).
6. **Battalion in Mass.** The Colour party shall be positioned between the two centre companies as follows:
 - a. **One Colour.** The Colour officer is positioned in line with the front rank of the leading platoons and the escorts in line with the rear rank of these same platoons.
 - b. **Two Colours.** The Colour officers and the Colour warrant officer are positioned in line with the front rank of the leading platoons and the sergeants in line with the rear rank of these same platoons (Figure 8-7-2).
7. **Review Order.** The Colour bearers shall advance as noted in Chapter 9, Section 2, paragraph 13 when ordered to take post in review order.

GUARDS OF HONOUR

8. When paraded with a guard of honour, Colours shall be positioned in review order prior to the arrival of the dignitary for whom the guard is being mounted.
9. When flags are paraded with a guard of honour, they maintain position and are not advanced in review order (see also Chapter 9, Section 2, paragraph 13).

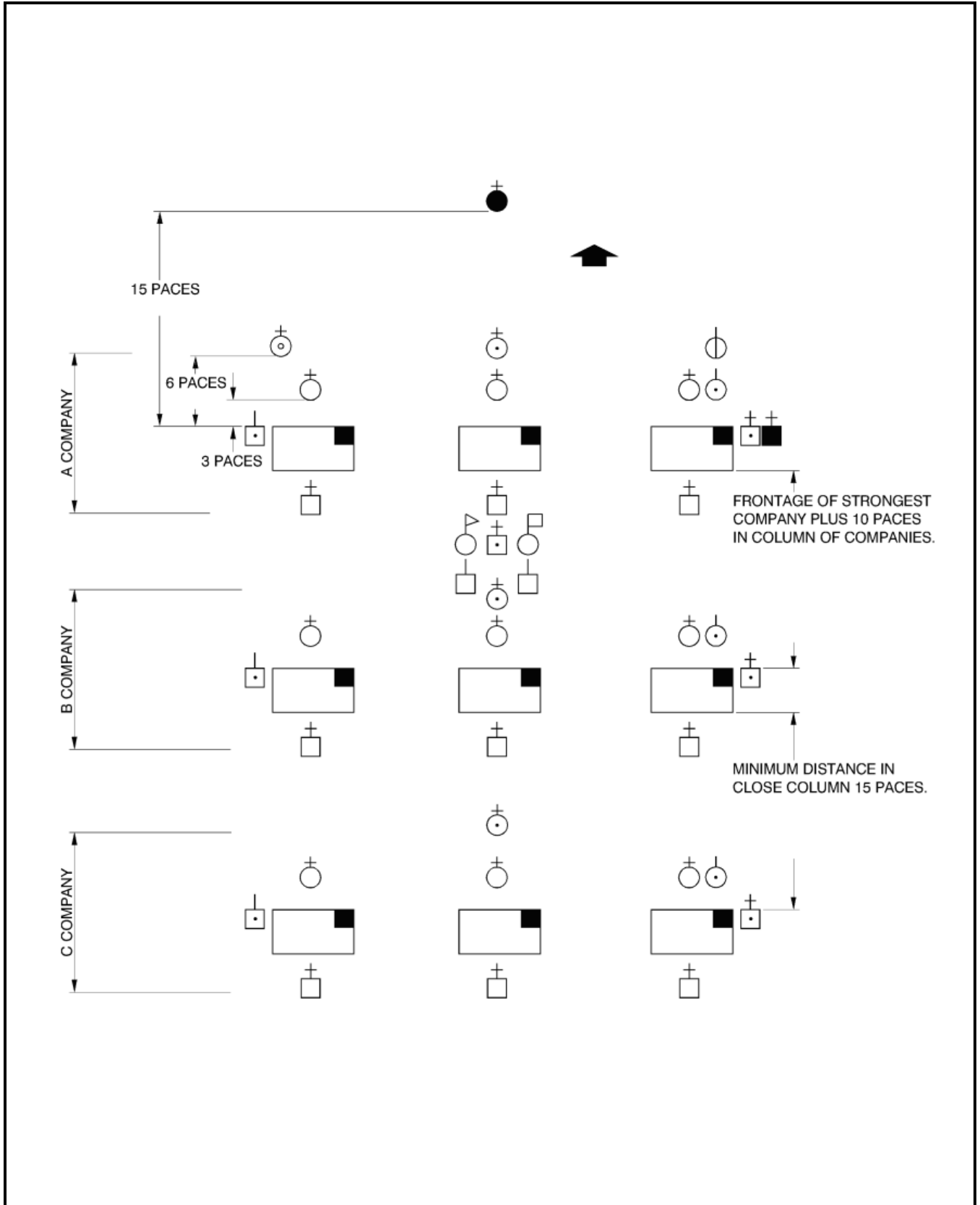

Figure 8-7- 1 Colours on Parade (Battalion in Close Column)

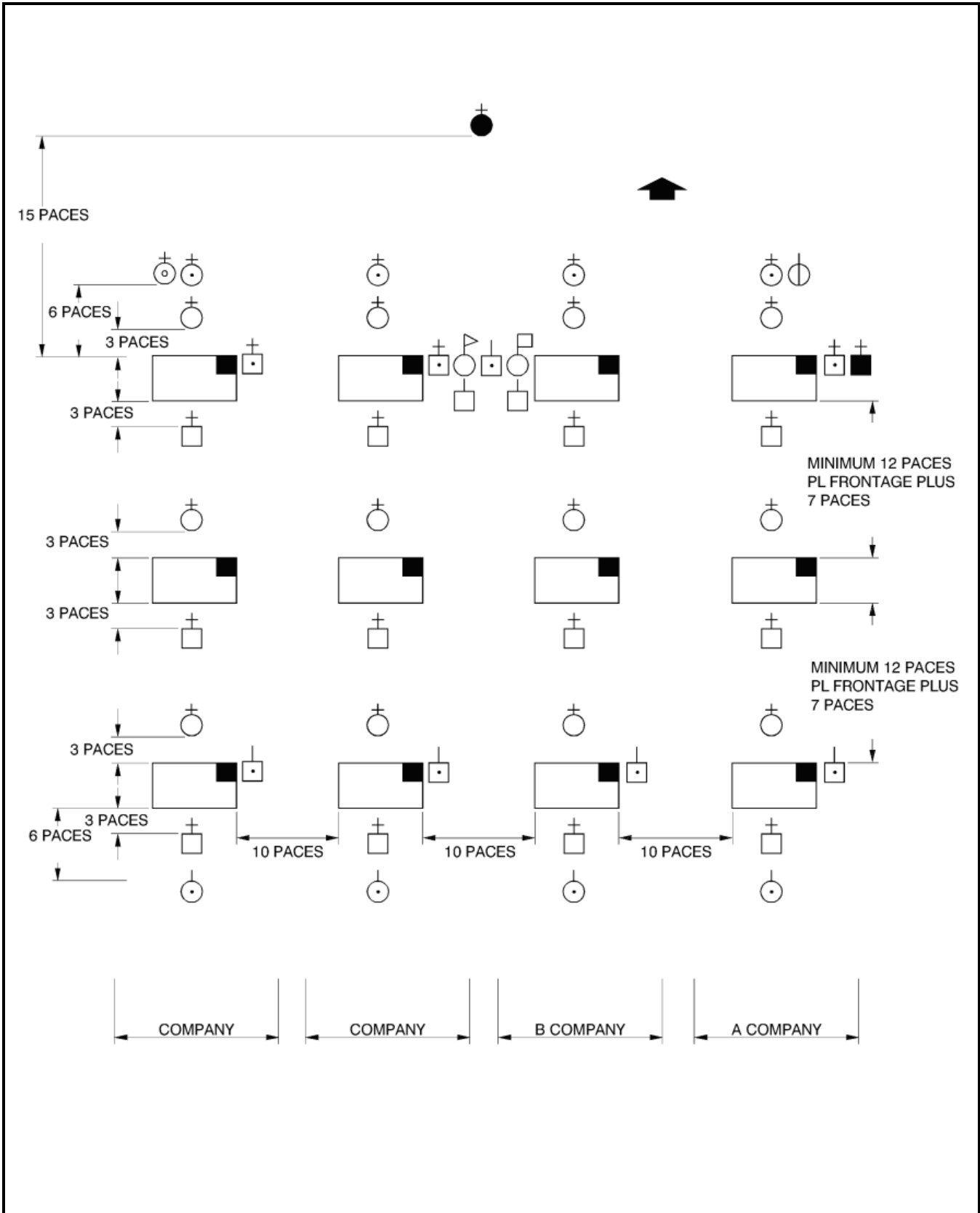

Figure 8-7- 2 Position Colours on Parade (Battalion in Mass)